

HPI wants to thank you for your confidence in its products.
 Please read this manual carefully to ensure years of enjoyment of this specialised high end electronic device.
 This manual shows you how to properly install the stator, flywheel, CDI and HT coil.

Stator Installation:

- Remove the original ignition from your engine.
- Depending on the engine's setup, a mounting plate is included in this set. This mounting plate serves as an adaptor between your engine and the 210 ignition. Fit the mounting plate on your engine.
- Locate the cable exit on your engine and position the stator according to this hole. If necessary, remove the plug (see backside) and lead the cable through the hole.
- Center the stator on the mounting plate (if present) or directly on your engine.
- Gently bolt the stator to your engine; do not tighten the bolts yet.

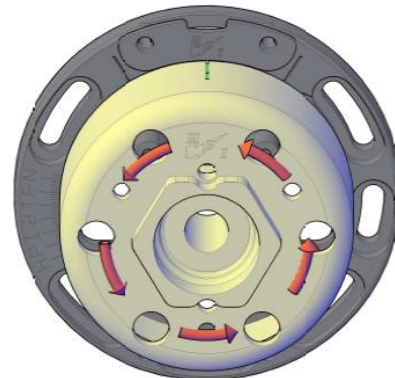

Flywheel installation:

The flywheel has to be placed on the crankshaft or otherwise on an axis which rotates at the same speed.

- Position the cylinder in its Top Dead Centre (TDC).
- Place the flywheel on the shaft, aligning the mark on the rotor with the mark on the cable cover. This position corresponds with 0° in the advance curve. (see backside image)
- The images on the right indicate which mark should be aligned according to the rotation direction. In both cases this is the middle of the cable cover.
- Double check that the flywheel does not touch the stator windings.
- Fasten the flywheel to the shaft.
- Check the position of the cylinder. If necessary adjust the alignment by turning the stator plate.
- Fasten the stator plate.

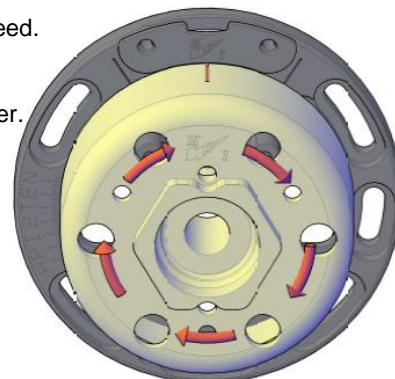

To gain performance, change the ignition curve with the TuneBox software.

Wiring instructions:

- **Light-coil** yellow
yellow ring Connect the 60W light coil to your light circuit or regulator.
Single phase regulators: connect **ring to GND**.
Two phase regulators: connect **both yellow wires** to the regulator.
- **HT-coil** orange
black ring Connect the HT-coil to the frame.
Plug the orange cable to the HT-coil,
Connect the black cable with ring to the
bracket of the HT-coil and to the frame.
- **Stator** 3-way plug Plug the 3-way connector of the stator directly into the CDI.
If you need to lead the cable through a narrow space,
See back side to remove the connector from the cable loom.
- **Kill** black/white Connect the black-white to frame / ground for an emergency stop.
- **Curve switch** yellow connect the curve button to these wires. (optional)
yellow/green switch the button to select the desired advance curve.

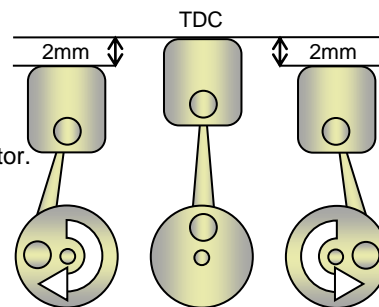

To minimize electrical interference, try to keep all cables at a safe distance from the HT cable.
 Fasten all the cables to the frame and keep them clear from hot places and moving parts.

Please attend to the following remarks:

- the CDI-unit and cables must not be exposed to **mechanical stress**.
- the CDI-unit must not be exposed to **excessive heat** (not behind the radiator, close to the cylinder or the exhaust).
- the CDI-unit must not be exposed to **electrical interferences** (not close to the ht-coil).
- the CDI-unit must not be directly exposed to **fluids** (water, gasoline, oil,...).
- **Do NOT** extend cables, this may cause interference and damage to the CDI or the engine.

ATTENTION

**When using the M6 holes of the flywheel, (fan, flywheel puller,...)
 Make Sure the bolts don't protrude inside the flywheel!
 Protruding bolts can damage the stator coils and void warranty.**

Flywheel puller - 210V251

Be careful not to damage the stator when removing the flywheel!
To safely remove the flywheel, HPI can provide you with a puller.
This is a widely applicable flywheel puller, M27 – 1 mm pitch – left thread.



Inertia disk – 210V257

If your engine requires a heavier flywheel, you can add an inertia disk to the 210 ignition. The inertia disk is a stainless steel disk of 95mm diameter, 280 grams, specially designed to centre-fit on the 210 flywheel.

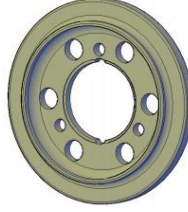

Fan blade – 210V256

Specially developed for the 210 ignition, to fit various Vespa engines. External diameter: 166mm.

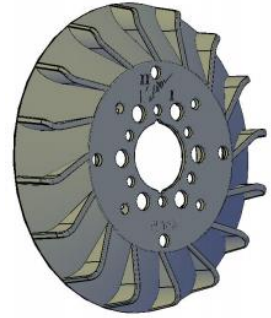

Curve switch - 210V064

For 2-curve CDI units, the curve select button comes in handy. Easy mountable on your handle bar .



Twin exit HT-coil - 210V007

The 210 ignition generates 2 sparks each revolution. Using a HT-coil with double exit, this ignition can be used on 2 cylinder (180°) engines.



Regulator Rectifier – 210V261

If you require a regulated voltage from the integrated 60W light coil, HPI can deliver a regulator – rectifier for all purposes:

- 12V D: battery,
- 12V AC: lights,
- 12V AC+DC

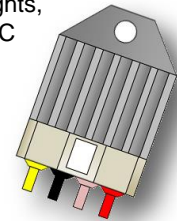

Ignition curves:

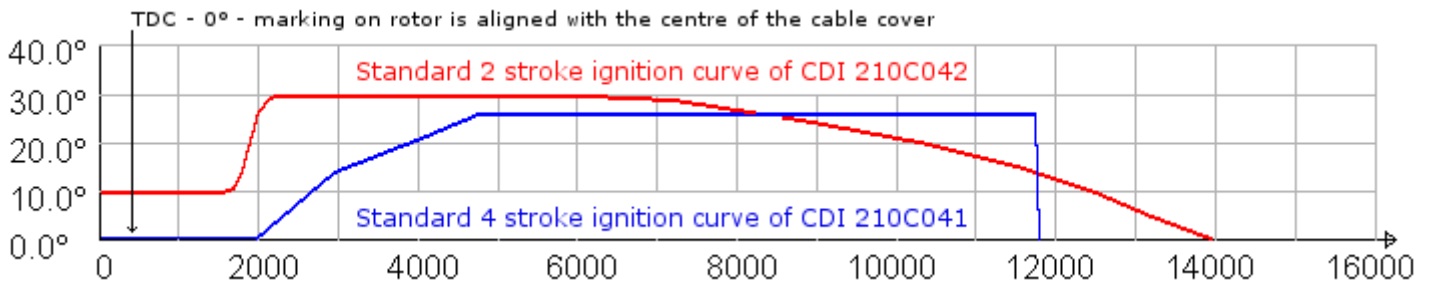

Connector removal:

